

# RP055 Medium Cast Pulley -19mm (3/4") Rope

## Data Sheet

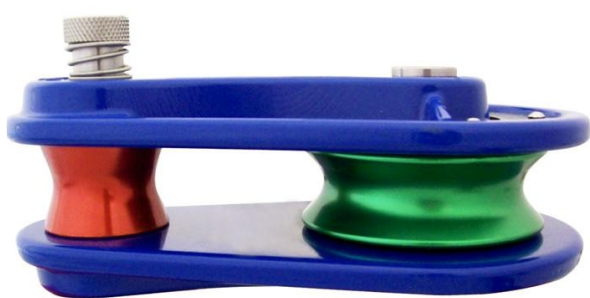

MBS 150kN / 33721lbf  
 WLL 30kN / 6744lbf  
 MAX ROPE Ø 19 mm / 3/4"  
 RP055  
 I/S/C  
 EN 1179:2011 CE 0120



climb. work. rescue.

# I/S/C

SOLUTIONS IN METAL

ISC Rigging Blocks have colour-coded Side Cheeks and Pulley Wheels, helping the user to easily identify the correct Block for the task. We have introduced a new fixed bollard dimension, which allows the user to fall in-line with rigging standard practice, whereby the Anchor/Topping Strop should be twice the Strength of the Working Line.

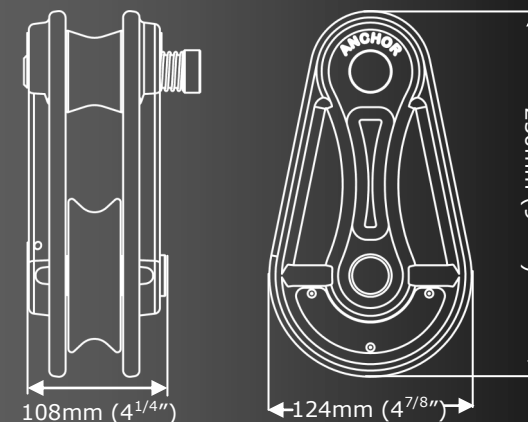

<b>Weight</b>	2.3kg (5.1lbs)
<b>Wheel Material</b>	Aluminium
<b>Body Material</b>	Aluminium
<b>Finish</b>	Powder Coated
<b>MBS</b>	150kN (33721lbf)
<b>WLL</b>	3000kg (6600lbs)

	<b>Working Line</b>	<b>Topping Strop</b>
<b>Size</b>	19mm (3/4")	29mm (1 1/8")
<b>MBS</b>	106kN (23400lb)	213kN (46800lb)

